

MEASUREMENT OF ELECTRON IMPACT IONIZATION FUNCTIONS FOR METAL ATOMS

G. M. Beilina, S. I. Pavlov, V. I. Rakhovskii, and O. D. Sorokaletov

Zhurnal Prikladnoi Mekhaniki i Tekhnicheskoi Fiziki, No. 2, pp. 94-96, 1965

A technique is developed for determining absolute values of the effective cross sections for ionization of atoms of substances with low vapor pressure employing the method of crossed atomic and electron beams. In order to eliminate the effect of residual gases, the atomic beam was modulated and the variable component of the ionic current measured using a U1-2 type electrometric amplifier and a ENO-1 type (S-1-4) electronic oscillograph, both precalibrated. The atomic concentration of the investigated substance in the ionization zone was determined from the weight of the condensate on a cooled collector. The electron impact ionization function for lead atoms was measured over an energy range extending from the ionization threshold to 150 eV. At the maximum of the ionization function, which corresponds to an energy of 55 eV, the cross section is $8 \cdot 10^{-16} \text{ cm}^2$. The total error of these measurements does not exceed 15%, if the energy spread in the electron beam is not worse than 0.35 eV.

The effective atomic ionization cross section for electron impact quantitatively characterizes the ionization process associated with interaction between electron and atom. This is one of the fundamental characteristics of atoms, a knowledge of which is necessary both to understand the electron shell structure of the atom and to solve a number of practical problems. Examples of such problems are: calculation of the ionization processes in the cathode region of an arc, application of mass spectrometry to quantitative measurements of components of mixtures with very different ionization cross sections, calculations for effective ion sources and powerful electron-beam systems used for welding and melting metals (ionization of the metal vapor results in space-charge compensation and a change in beam geometry), study of the processes in thermoelectric converters.

Interest is mainly focused on the ionization function, the relation between the absolute value of the ionization cross section and the electron energy. So far, only a very limited number of elements have been studied. Measurements of the absolute ionization cross section have been used to obtain the ionization functions for only three metals Hg, Na, K and the gases H_2 , H_1 , He, Ne, Ar, N_2 , N, O_2 , O [1-4]. Funk [5] measured the ionization cross sections of Na and K by the atomic beam method. On account of the strong effect of residual gases, the accuracy of these measurements was necessarily poor. In the opinion of the authors of [6], Funk's results give only the order of magnitude of the cross section. The ionization cross section of silver was measured in [7], but the ionization function was not recorded.

Lastly, for certain gases (Kr and Xe) and alkali metals (Li, Na, K, Rb, Cs), the relative change of the ionization function with electron energy has been measured [1, 8]. Naturally, these results are of only limited value.

In view of the above, we have developed a method of measuring absolute values of the ionization cross section, particularly for substances with low vapor pressure, including metals. This arose from the requirements of certain practical problems in technical physics.

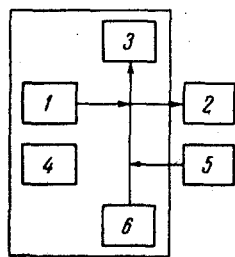

Fig. 1

In order to determine the absolute ionization cross section for electron impact, it is necessary to measure the total number of ions generated by an electron beam of known intensity and energy in passing through a region occupied by neutral atoms of known concentration.

Previous work of this type has suffered from a number of errors: neglect of residual gases [5], inaccurate measurement of both ion and electron currents [9], measurement of only a fraction of the ion current [10], failure to measure the energy spread of the electron source.

In order to remove these particular sources of error, we developed a new technique, which is illustrated schematically in Fig. 1, where 1 represents the electron source, 2 the variable ion current measuring system, 3 the neutral atom collector, 4 the vacuum measuring system, 5 the atomic beam chopper, and 6 the source of neutral atoms. The investigated substance is introduced into the ionization zone in the form of an atomic beam. This atomic beam is ionized by a transverse electron beam of given energy and intensity. Measuring the ion current gives the number of ions produced. The concentration of neutral atoms in the ionization zone is determined gravimetrically from the weight of condensate. The measured parameters make it possible to determine the ionization cross section.

The atomic beam source used in our experiments consisted of a quartz crucible and a molybdenum plate cover with a slit. A bifilar tungsten spiral was used to heat the crucible, which had molybdenum screens to reduce the radiation loss. A diaphragm system controlled the shape and intensity of the atomic beam.

In order to separate the ion current of the investigated substance from the residual gas background, the atomic

beam was modulated by means of a chopper operated at a given frequency by an external electromagnet. Ionization was produced by means of an electron gun with an oxide cathode and a focusing system employing a longitudinal magnetic field. The presence of this magnetic field completely eliminated both elastic scattering of electrons and photoemission from the ion collector. The use of batteries to supply the electron gun eliminated voltage pulsations. The ion current was measured by a type Y1-2 electrometric amplifier, the output voltage of which was fed to a type ENO-1 (S-1-4) oscillograph with a dc amplifier.

The concentration of neutral atoms in the ionization zone was determined from the rate of condensation on the collector, which was cooled by liquid nitrogen. In order to obtain a series of beam intensity measurements, the collector had several bases, which were weighed on a MA-20 balance, correct to 10^{-5} grams, both before and after deposition.

Our main object was to develop a method of measuring the impact ionization functions of metal vapors. Hence lead, which has a relatively low vapor pressure, low melting point, and practically monatomic vapor composition, was chosen for investigation.

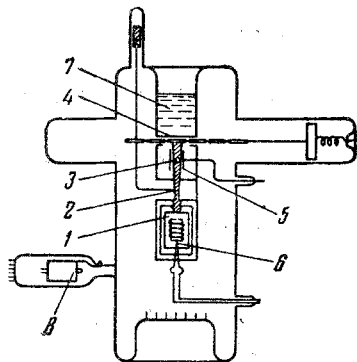

Fig. 2

The experimental apparatus, which was assembled from vacuum-degassed components, is shown in Fig. 2, where 1 is the source of neutral atoms, 2 the atomic beam chopper, 3 the electron beam, 4 the neutral atom collector, 5 the ion collector, 6 a thermocouple, 7 the cooling system for the neutral atom collector, and 8 an LM-2. The investigated metal (lead) was thoroughly degassed by multiple remelting in vacuum. After assembly the apparatus was sealed to a vacuum unit and then underwent special treatment during which the envelope was completely annealed, the oxide cathode of the electron gun activated, and the vaporizer preheated. Finally, the envelope was sealed off at a pressure of less than $2 \cdot 10^{-7}$ mm Hg.

Measuring the ionization function, especially in the initial section, imposes rigorous requirements on the energy uniformity of the electron source. In most cases [1-4, 8, 9] the energy spread of the electron beam was not determined. The reliability of the results obtained is therefore uncertain. Rough estimation of the mean value of the initial electron energy spread based on cathode temperature calculations leads to a serious underestimate. Therefore we first determined the order of the energy spread of the investigated electron source using an electrostatic selector. In addition, in order to allow for the contact potential difference, we recorded delay curves, which permit the simultaneous evaluation of the energy spread of the beam electrons. The results showed that the energy spread of the investigated system is not worse than 0.35 eV. This value was obtained with currents up to 10^{-6} a. A type M-95 galvanometer was used to measure the beam current.

The type U1-2 electrometric amplifier was calibrated by means of a special calibration unit, so as to obtain absolute values in measuring the modulated ion current. The error of the ion current measurements was not more than 8%.

The ionization function was measured in the following way. The apparatus was connected to the measuring circuit, the operation of the electron gun was checked, and the residual gas ion current was measured.

Then the vaporizer heater supply was turned on. A continuous check on the ion current was maintained while the vaporizer was brought into the working regime. After the working temperature was reached, the apparatus as a whole was adjusted. At this point the field strength at which all the ions were attracted to the collector was selected. Then condensate collector base was changed and the ionization function recorded several times at several different values of the electron current. The use of several bases revealed that during the experiment the lead vaporization rate remained constant to an accuracy of not less than 4%.

The results (Fig. 3) represent the average of twelve measurements. The scatter does not exceed 8%, that is, the experimental points all lie within the limits of the measuring error. The ionization cross section was determined using the expression

$$Q = I_+ m b v / I_- M. \quad (1)$$

Here Q is the effective ionization cross section, I_+ the ion current, I_- the electron current, m the mass of a lead atom, t the vaporization time, b the atomic beam width in the vicinity of the electron beam, v the mean velocity of beam atoms, and M the mass of the condensate accumulated during the experiment.

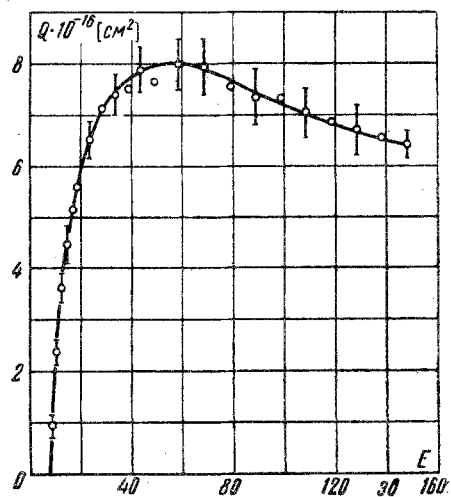

Fig. 3

The initial section of the ionization function has a slope $0.7 \cdot 10^{-16} \text{ cm}^2 \text{ volt}^{-1}$, that is, the rate of change is relatively small.

The ionization function reaches 50% of the maximum at an electron energy 6 eV above the threshold value. This makes it possible to assert that the presence of a certain spread of electron energy (0.35 eV) does not lead to serious distortion of the nature of the ionization function. The total measuring error calculated according to Eq. 1 does not exceed 15%.

The authors consider themselves deeply indebted to V. L. Granovskii for his guidance and advice. They are also grateful to Z. I. Sinitsinaya and A. A. Mal'kov for preparing the experimental apparatus.

REFERENCES

1. Atom und Molecularphysik, 1 Teil, Atome und Ionen, Berlin, Göttingen, Heidelberg, 343-345, 1950.
2. W. L. Fite and R. T. Brackman, "Collisions of electrons with hydrogen atoms," Phys. Rev., vol. 112, p. 1141, 1958.
3. E. W. Rothe, L. L. Marino, R. H. Neynaber, and S. M. Trujillo, "Electron impact ionization of atomic hydrogen and atomic oxygen," Phys. Rev., vol. 125, p. 582, 1962.
4. A. C. Smith, E. Caplinger, R. H. Neynaber, E. W. Rothe, and S. M. Trujillo, "Electron impact ionization of atomic nitrogen," Phys. Rev., vol. 127, p. 1647, 1962.
5. H. Funk, Über die Ionisierung von Alkaliatomen durch langsame Elektronen," Ann. Phys., vol. 4, p. 149, 1930.
6. Messi and Barhop, Electron and Ion Collisions [Russian translation], Izd. inostr. liter., 1958.
7. A. P. Lyubimov, S. I. Pavlov, V. I. Rakhovskii, and N. G. Zaitseva, "Method of measuring effective impact ionization cross sections and ionization coefficients of metal atoms," Izv. AN SSSR, ser. fiz., vol. 27, no. 8, p. 1060, 1963.
8. G. O. Brink, "Ionization of alkali atoms by electron bombardment," Phys. Rev., vol. 127, p. 1204, 1962.
9. K. T. Compton and C. C. Van Voorhis, "Probability of ionization of gas molecules by electron impact," Phys. Rev., vol. 27, p. 724, 1926.
10. W. B. Nottingham, "Ionization and excitation in mercury vapor produced by electron bombardment," Phys. Rev., vol. 55, p. 203, 1939.
11. A. N. Nesmeyanov, Vapor Pressure of Chemical Elements [in Russian], Izv. AN SSSR, 1961.

29 October 1964

Moscow